



**National Research
Council Canada**

**Conseil national
de recherches Canada**

Institute for
Research in
Construction

Institut de
recherche en
construction

CCMC 12893-R



*EVALUATION
REPORT*

DIVISION	07273
Issued	1999-01-12
Re-evaluated	2003-01-29
Revised	2004-04-15
Re-evaluation due	2005-01-12

Re-Evaluation
in process

*Airmetic® 0223/Heatlok® 0240/Polar Foam
7300/Burnaby Air Barrier – Air Barrier Material*

Demilec Inc.
870, Curé-Boivin
Boisbriand (Québec)
J7G 2A7

Tel.: (450) 437-0123
Fax: (450) 437-2338

1. Purpose of Evaluation

The proponent sought confirmation from the Canadian Construction Materials Centre (CCMC) that “Airmetic® 0223/Heatlok® 0240”* spray urethane foam insulation can serve as an air barrier material, within the Demilec Inc.-specified “Airmetic® 0223/Heatlok® 0240” air barrier system, in compliance with the intent of the National Building Code of Canada (NBC) 1995.

* These products will be referred to as “Airmetic® 0223/Heatlok® 0240” throughout this report for the sake of simplicity, but also included in these names are references to the other private label names.

2. Opinion

Subject to the limitations and conditions stated in this report, test results and assessments provided by the proponent show that “Airmetic® 0223/Heatlok® 0240” complies with CCMC’s Technical Guide for Air Barrier Material, MasterFormat Number 07273, dated 97-05-06, and provides a

*This Report is provided without representation, warranty, or guarantee of any kind, expressed or implied, and the National Research Council of Canada (NRC) provides no endorsement for any evaluated material, product, system or service described herein.
NRC has evaluated the material, product, system or service described herein only for those characteristics stated herein. The information and opinions in this Report are directed to those who have the appropriate degree of experience to use and apply its contents.
NRC accepts no responsibility whatsoever arising in any way from any and all use or reliance on the information contained in this Report. NRC is not undertaking to render professional or other services for or on behalf of any person or entity nor to perform any duty owed by any person or entity to another person or entity.*

level of performance equivalent to that required in:

- NBC 1995, Sentence 5.4.1.2.(1) and Appendix A-9.25.3.2.

Canada Mortgage and Housing Corporation permits the use of this product in construction financed or insured under the National Housing Act.

3. Description

This report addresses the performance of “Airmetic® 0223/Heatlok® 0240” as an air barrier ‘material’ within the Demilec Inc.-specified “Airmetic® 0223/Heatlok® 0240” air barrier system. The Demilec Inc.-specified “Airmetic® 0223/Heatlok® 0240” air barrier ‘system’ has not been evaluated but is presented in Appendix A below as additional information for the convenience of building officials.

“Airmetic® 0223/Heatlok® 0240” insulation material, if installed as part of the designated air barrier system, will serve a dual function in the wall assembly: as the designated air barrier system and an exterior insulation. The use of “Airmetic® 0223/Heatlok® 0240” as an insulation is covered under CCMC evaluation report no. 12380-R.

The foam system “Airmetic® 0223/Heatlok® 0240” consists of two components. The two components are mixed on site by a qualified licensed installer with fixed-ratio 1:1 positive displacement equipment. The final cured product has a min/max density of 31.3/35.2 kg/m³ and an assigned design thermal resistance of 1.05 m² ·°C/W per 25 mm (R6 per inch). See CCMC 12380-R for information on the application of this product as an insulation.

“Airmetic® 0223/Heatlok® 0240” as an air barrier material must be installed at a minimum thickness and density specified below.

4. Usage and Limitations

“Airmetic® 0223/Heatlok® 0240” spray urethane foam insulation has demonstrated sufficiently low air permeance, when having a 25.4 mm thickness and a minimum density of 35.2 kg/m³,

equivalent to the materials outlined in NBC 1995 Appendix note A-9.25.3.2. and Sentence 5.4.1.2.(1), to be the principal plane of airtightness in an air barrier system.

When “Airmetic® 0223/Heatlok® 0240” material, having low air and vapour permeance, is installed as part of the airtight element of the designated air barrier system, the vapour barrier must comply with NBC Sentence 9.25.4.2.(2). Also, in this case, “Airmetic® 0223/Heatlok® 0240” must be installed at a 25.4 mm or greater thickness to comply with NBC Article 9.25.1.2. for the respective geographical location.

For the control of air leakage a conforming installation must be:

- installed with a minimum thickness of 25.4 mm as exterior insulation over exterior sheathing or masonry back-up wall;
- installed according to Demilec Inc.’s air barrier installation guidelines contained in “Demilec Typical Details for the design of the Building Envelope, Heatlok 0240” published July 1999 (examples of the installation details are presented as ‘Additional Information’ below in Appendix A).

In addition, due to low water vapour permeance (WVP) properties, fire performance, and issues related to the spraying process (see CCMC 12380-R for more complete details), the following conditions also apply:

- Since the WVP value is less than the maximum 60 ng/Pa·s·m² (i.e. when installed with a 25.4 mm thickness on a substrate such as wood sheathing or concrete block), as permitted in Article 9.25.1.2. of the NBC 1995, the wall assembly must conform to Table 9.25.1.2. When “Airmetic® 0223/Heatlok® 0240” is installed on a substrate as the sole wall insulation, such as on concrete block, it may also qualify as the designated vapour barrier if the installed thickness meets Sentence 9.25.4.2. (1) or 5.5.1.2. (1).

-
- The sprayed material shall completely cover the surfaces and the product must be applied in passes of between 15 mm and 50 mm thick.
 - For proper adhesion the substrate surface must be clean, dry and free of oil, grease, loose scale, rust or other unsuitable material.
 - As required in Article 9.25.2.3. of the NBC 1995, the insulation shall be installed so that there is a reasonably uniform insulating value over the entire face of the insulated area.
 - The product shall not be used in exposed interior or exterior locations, thermal barrier protection is required.
 - The insulation shall be kept at least 75 mm, or as required in building regulations and safety codes, from heat-emitting devices such as recessed light fixtures and chimneys.
 - This product shall not be used where it may be in continuous contact with water.
 - The product shall not be installed after the expiry date printed on the label of each container. The product has a shelf life of 6 months from the date of manufacture.
 - The continuous service temperature of the insulation shall not exceed the range of -60°C to 80°C.
 - See current CCMC 12380-R for details on latest changes to permitted coverage over electrical wires and permitted time-to-occupancy based on emissions of the site-manufactured foam insulation.
 - The two components of, "Airmetic® 0223/Heatlok® 0240", must have their respective containers (i.e. drums) identified by the phrase "CCMC 12380-R" and "CCMC 12893-R."

The manufacturer of "Airmetic® 0223/Heatlok® 0240" mandates that the spray foam insulation material shall be manufactured on site by qualified installers licensed by a recognized third-party organization. The third-party organization shall be recognized for its training program and follow-up inspection of installers trained to spray urethane foam insulation in accordance with CAN/ULC-S705.2-98, "Standard for Thermal Insulation-Spray Applied Rigid Polyurethane Foam, Medium Density, Installer's Responsibilities-Specification."

The third-party licensing and follow-up inspection agency for the "Airmetic® 0223/Heatlok® 0240" product shall be CUFC/NECA (Canadian Urethane Foam Contractors' Association/National Energy Conservation Association). The installation procedure shall follow the installer's manual of instructions. A copy of those instructions shall be available at the jobsite at all times during the installation. All installers shall present their CUFC/NECA licensing card upon request by the building official.

It should be noted that a concealed air space exceeding 25 mm in width must contain proper fire stopping, in accordance with Subsection 9.10.15. of the NBC 1995.

5. Performance

Testing was conducted at an independent laboratory recognized by CCMC. The results of testing "Airmetic® 0223/Heatlok® 0240" air barrier material are summarized in Table 1.

The durability assessment of "Airmetic® 0223/Heatlok® 0240" is covered under CCMC report no. 12380-R.

Table 1. Results of Testing “Airmetic® 0223/Heatlok® 0240 to CCMC Technical Guide for Air Barrier Materials

Test	Requirement	Result
Five – 1 m ² , 25.4-mm-thick specimens (skin removed) tested and measured for air permeance at a minimum of six air pressure differentials (ΔP) between 0 and 250 Pa.	Air Leakage Rate at 75 Pa ΔP (Based on Linear Regression of 30 data points) ≤ 0.02 L/(s·m ²)	0.00014 L/(s·m ²)

For more information contact:

Bruno Di Lenardo, P.Eng.
(613) 993-7769

*Issued by the Institute for Research in Construction
under the authority of the National Research Council*

John Flack, Ph.D.
Manager, CCMC

Note: Readers are asked to refer to limitations imposed by NRC on the interpretation and use of this report. These limitations are included in the introduction to CCMC’s Registry of Product Evaluations, of which this report is part.

Readers are advised to confirm that this report has not been withdrawn or superseded by a later issue by referring to <http://irc.nrc.gc.ca/ccmc>, or contacting the Canadian Construction Materials Centre, Institute for Research in Construction, National Research Council of Canada, Montreal Road, Ottawa, Ontario, K1A 0R6; Telephone (613) 993-6189, Fax (613) 952-0268.

APPENDIX A

Additional Information

An air barrier material as part of an air barrier system

CCMC has not evaluated the performance of the “Airmetic® 0223/Heatlok® 0240” air barrier ‘system’ in conformance with NBC 1995 Article 9.25.3.2. However, CCMC’s opinion is that an air barrier system using this material and installed in conformance with the details as outlined below and in Demilec Inc.’s air barrier installation guidelines contained in “Demilec Typical Details for the design of the Building Envelope, Heatlok 0240” published July 1999, should satisfy the requirements for continuity of the air barrier system in NBC 1995 Articles 9.25.3.1 and 9.25.3.3.

Discussion

Authorities having jurisdiction should be aware that this system differs from the typical air barrier approach that uses a flexible membrane as the principal plane of airtightness. In this other approach, the membrane (i.e. polyethylene sheet) is normally sandwiched between two other materials so that it is not required to resist, on its own, the full force of indoor/outdoor pressure differences induced by stack effect, mechanical systems and, most importantly, wind.

In a system in which the spray urethane and transition membrane is applied to the outer surface of the wall sheathing or concrete block, such as the “Airmetic® 0223/Heatlok® 0240” air barrier ‘system,’ it must have adequate adhesion to resist the anticipated wind loads. CCMC’s evaluation of the “Airmetic® 0223/Heatlok® 0240” air barrier material does not include the evaluation of this adhesive strength or the strength of the continuity details with the transition membrane at joints.

The authority having jurisdiction therefore must determine whether the “Airmetic® 0223/Heatlok® 0240” air barrier system, described herein, meets the intent of NBC 1995 Sentence 9.25.3.2.(1) as being an ‘effective’ barrier for the proposed construction in the

proposed geographical/ climate area. For example, the authority having jurisdiction may deem the proposed “Airmetic® 0223/Heatlok® 0240” air barrier system adequate for buildings in urban areas, sheltered sites or low wind areas, based on their experience, while it may be deemed inadequate in high wind and exposed sites in rural or coastal areas.

An air barrier ‘system’ checklist for the authority having jurisdiction to consider is the following:

An air barrier system must:

- (i) have an acceptable low air leakage rate,
- (ii) be continuous,
- (iii) be durable,
- (iv) have sufficient strength to resist the anticipated air pressure load, and
- (v) be buildable in the field.

Installation details

“Airmetic® 0223/Heatlok® 0240” material is applied over exterior wall sheathing or concrete block complying with the NBC. It does not contribute to an air barrier system until it is joined to the other components that make up the air barrier system of the building. Demilec Inc.’s air barrier installation guidelines contained in “Demilec Typical Details for the design of the Building Envelope, Heatlok 0240” outlines how “Airmetic® 0223/Heatlok® 0240” material must be joined to the foundation wall, to windows and doors, to penetrations in the wall and to the ceiling air barrier, thus forming the system.

A successful air barrier system installation is predicated on sequencing during construction. Coordination is required during erection of framing and after completion of the air barrier system to ensure that no other trade breaches the integrity of the installed air barrier system.

The “Airmetic® 0223/Heatlok® 0240” air barrier system is defined as possessing the following features:

i) "Airmetic® 0223/Heatlok® 0240" spray urethane material as the principal material in the plane of airtightness;

ii) Accessories for continuity comprising:

A modified-bituminous transition membrane (i.e. peel-and-stick or thermally fused) compatible with polyurethane spray and able to resist the polyurethane curing temperature; and

Sealants around window and door openings;

iii) Durability:

Material meets CAN/ULC-S705.1-98, "Standard for Thermal Insulation-Spray Applied Rigid Polyurethane Foam, Medium Density, Material-Specification";

iv) System component for strength:

A structural substrate such as structural sheathing or concrete block wall designed to withstand the anticipated loads.

v) Site construction of air barrier system:

To be installed in the field by CUFCA/NECA- trained installers following the "Airmetic® 0223/Heatlok® 0240" air barrier system details and reviewed by building officials.

Figures 1 to 4 outline typical construction details on the installation of the "Airmetic® 0223/Heatlok® 0240" air barrier system. See "Demilec Typical Details for the design of the Building Envelope, Heatlok 0240" for more complete detailing.

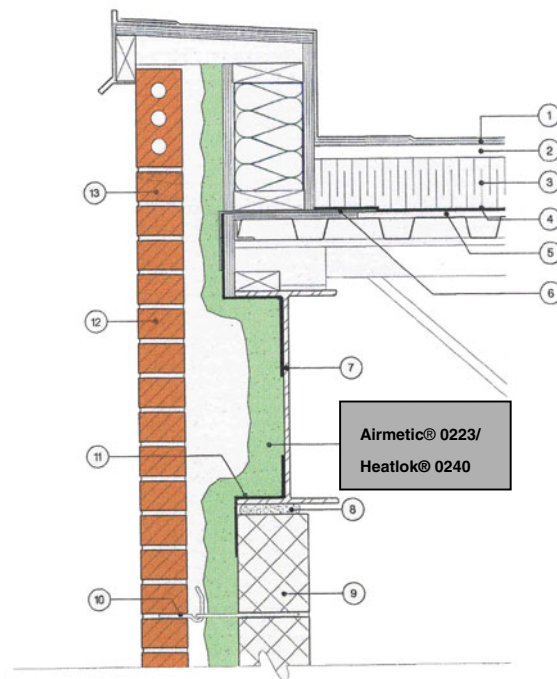

Figure 1. Exterior Wall Cross-Section

Example of Continuity Across Joints with Transition Membrane (#11). See manufacturer's manual for complete drawing and legend for other identified components.

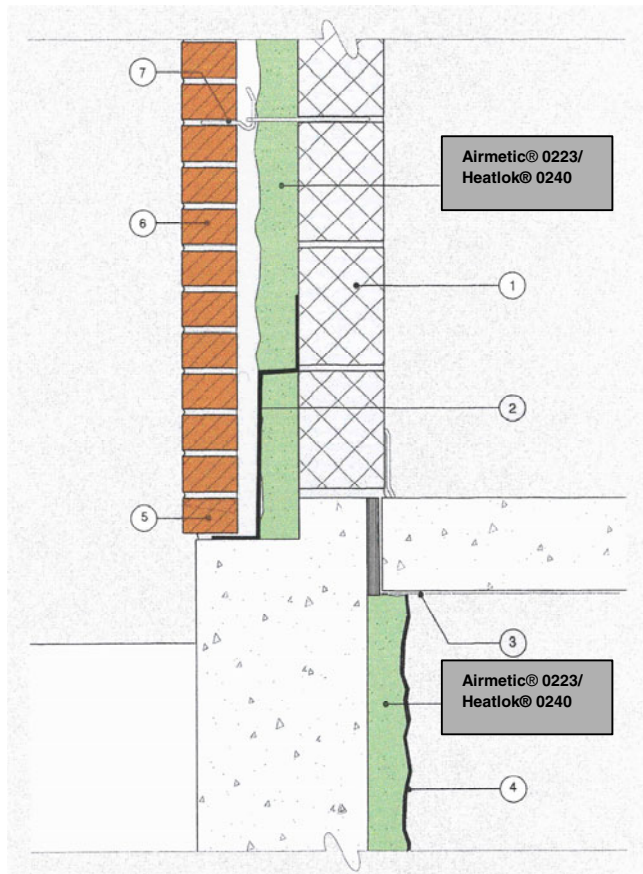

Figure 2. Typical Bottom Foundation Connection Detail (Masonry Wall)

Since the foundation wall is designated as part of the air barrier system, in this case, a flashing membrane (#2) must be sealed to the foundation wall to maintain the continuity of the plane of airtightness. See manufacturer's manual for complete drawing and legend for other identified components.

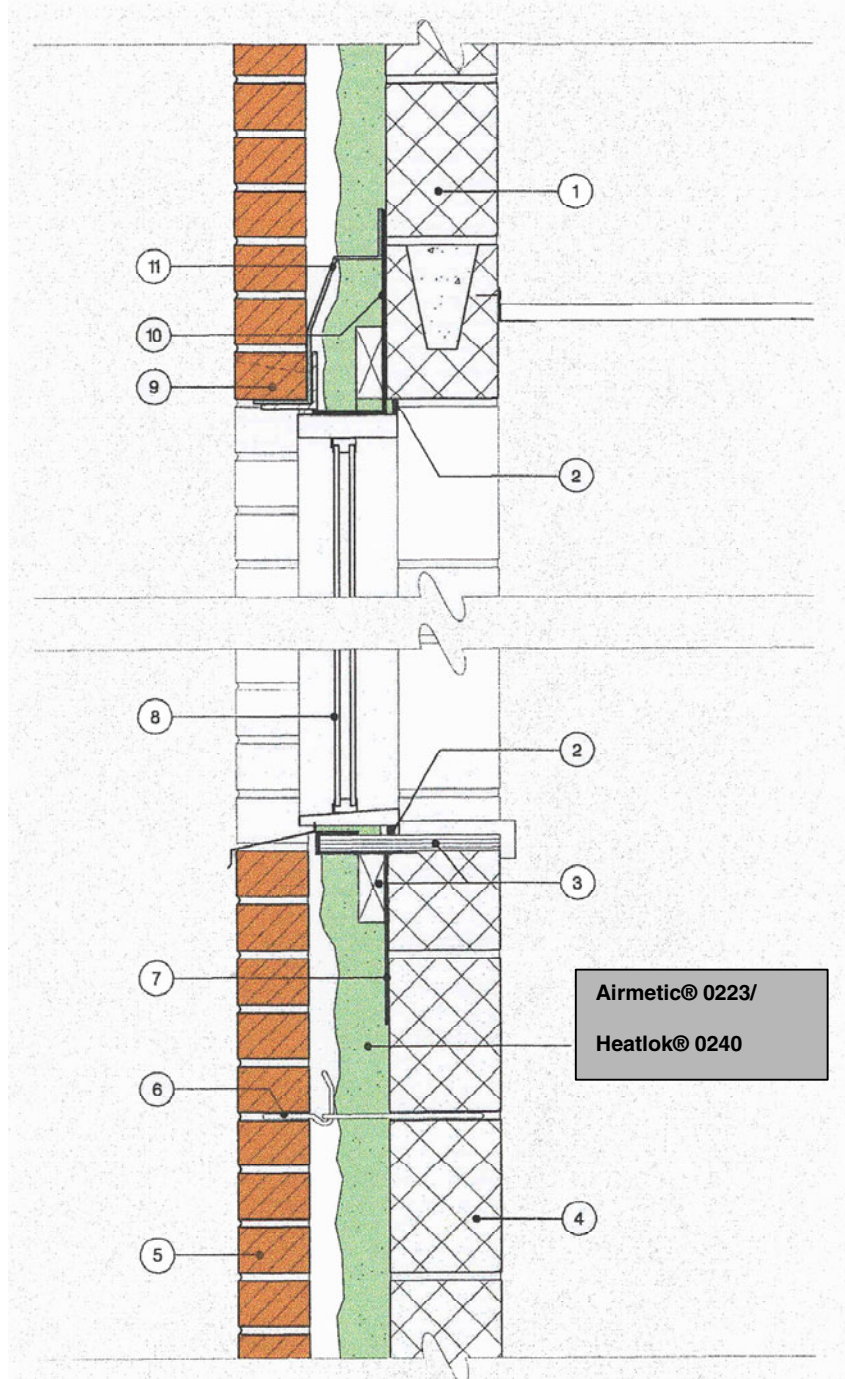

Figure 3. Typical Continuity at Windows

Note that sealant(#2) with backer rod is used, the transition membrane (#10) and urethane are being used to seal against the window frame. All penetration, construction or control joints in an exterior wall assembly must be bridged by a sealant or a transition membrane as part of the "Airmetic® 0223/Heatlok® 0240" air barrier system. See manufacturer's manual for complete drawing and legend for other identified components.

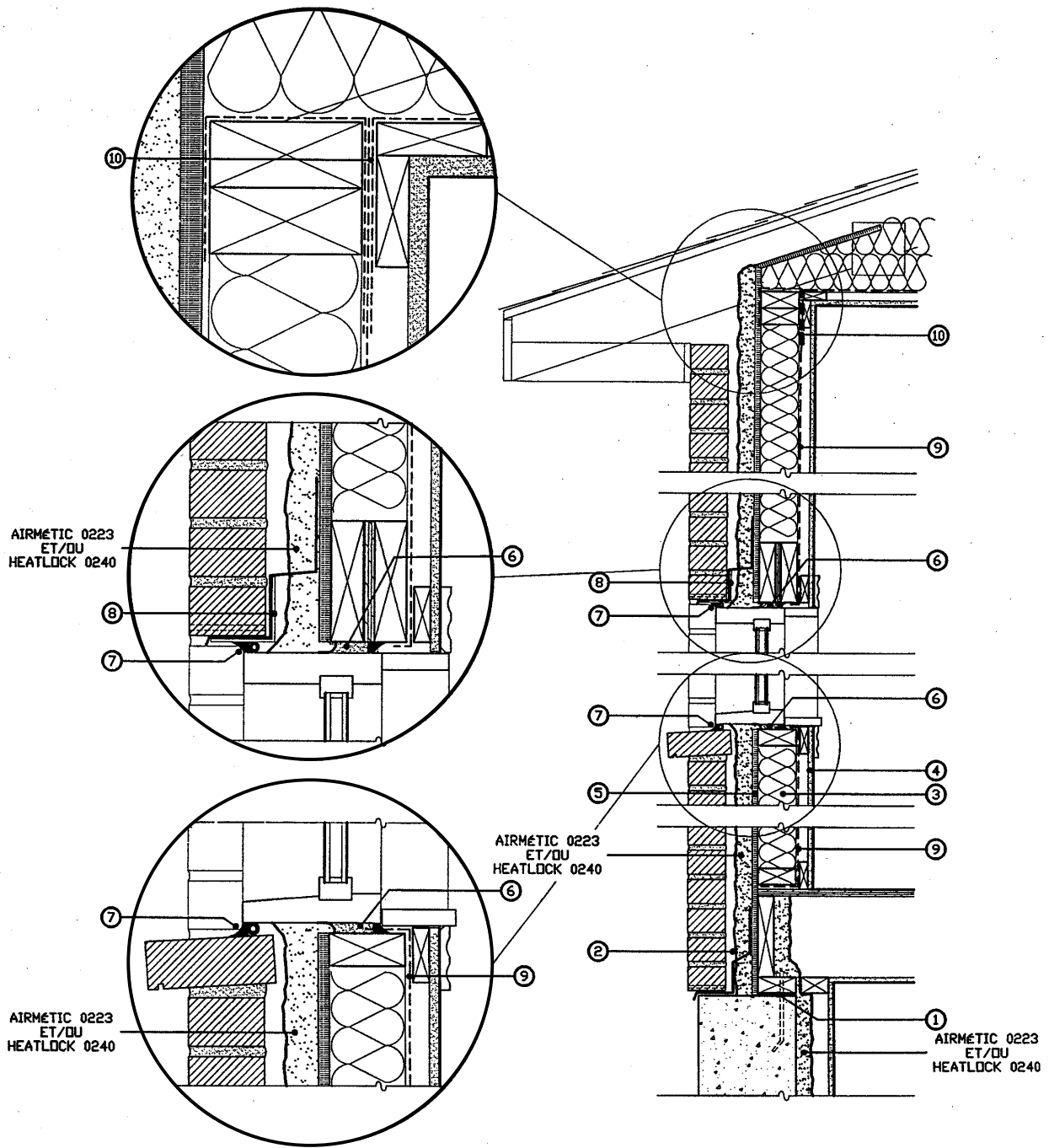

Figure 4. Typical Continuity Details in Woodframe Construction

Continuity at foundation walls maintained with "Airmetic® 0223/Heatlok® 0240" adhesion, at windows with "Airmetic® 0223/Heatlok® 0240" and backer rod/sealant (#7) and with ceiling polyethylene vapour/air barrier using polyethylene overwrap (#10). See manufacturer's manual for complete drawing and legend for other identified components.